



CAR TYRES



TyreSafe[®]

SAFE TYRES SAVE LIVES [tyresafe.org](https://www.tyresafe.org)





Car Tyres and Your Safety

Tyres are the only parts of the car which are in contact with the road. Safety in acceleration, braking, steering and cornering all depend on a relatively small area of road contact. It is therefore of paramount importance that tyres should be maintained in good condition at all times and that when the time comes to change them the correct replacements are fitted.

The original tyres for a car are determined by joint consultation between the car and tyre manufacturers and take into account all aspects of operation. It is recommended that changes in tyre size or type should not be undertaken without seeking advice from the car or tyre manufacturers, as

the effect on car handling, safety and clearances must be taken into account.

In some other European countries it is illegal to use replacements which differ in certain respects (e.g. size, load, and speed rating) from the tyre fitted originally by the vehicle manufacturer.

Tyres are a high-tech composite product, the result of over 100 years of continuous development. The overwhelming majority of tyres on the road today are of radial construction.

Some tyres, known as **Self Supporting Run Flat tyres**, are designed to provide a limited run on period following a puncture.

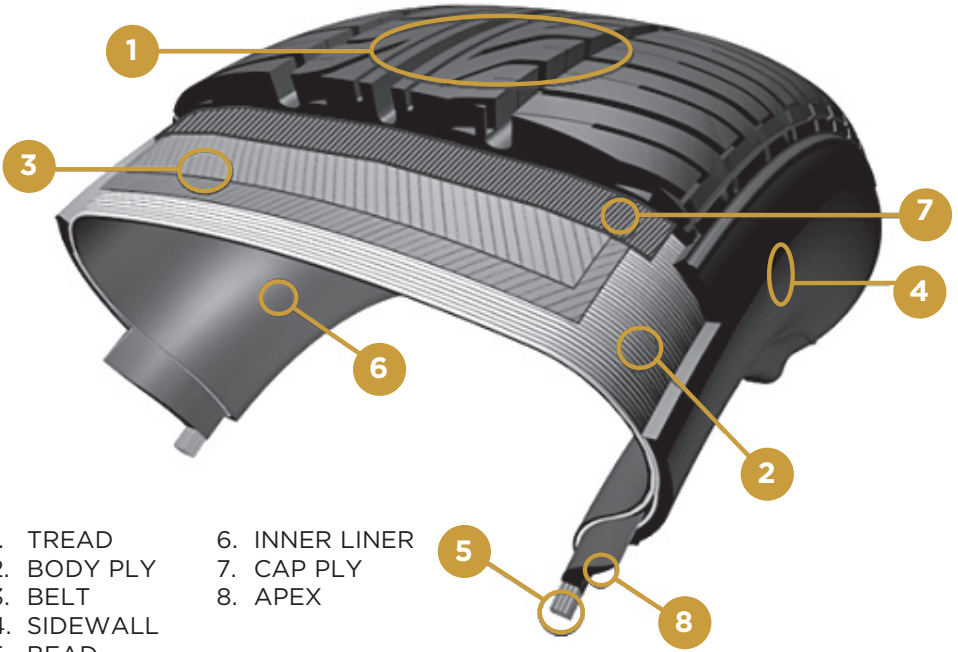

- | | |
|-------------|----------------|
| 1. TREAD | 6. INNER LINER |
| 2. BODY PLY | 7. CAP PLY |
| 3. BELT | 8. APEX |
| 4. SIDEWALL | |
| 5. BEAD | |

Tyres offering various levels of run flat performance are available. Tyres identified by the letters “RF” in the size marking are able to run uninflated for at least 50 miles (80 km) at a maximum speed of 50 mph (80 km/h). To accompany the use of run flat tyres it is essential that the vehicle is equipped with an operational Tyre Pressure Monitoring System.

The choice of tyres can have a considerable bearing on a vehicle’s handling. It is preferable to have tyres with the same tread pattern on each axle and ideally on all wheel positions. It is strongly recommended not to mix conventional and run flat tyres on the same vehicle. Particular care is required if retro-fitting run flat tyres as other modifications to the vehicle may be necessary.

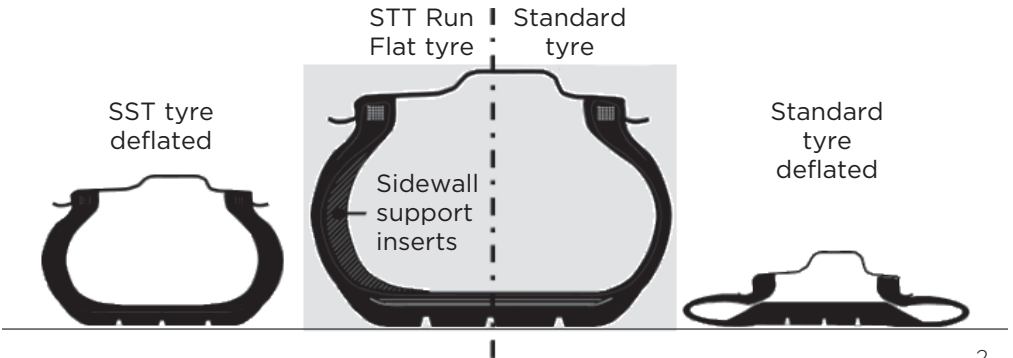



KEEP THE PRESSURE CORRECT

Correct inflation pressure is vital for optimum braking and cornering performance and to maximise tyre service life. Recommended tyre inflation pressures for your vehicle under different operating conditions can be found in the vehicle handbook and/or on a placard mounted on the vehicle. In the absence of these sources of information you should consult the vehicle dealer or manufacturer.

Prolonged under-inflation causes excessive flexing, deterioration of the casing and rapid wear of the tread shoulders. The vehicle will also consume more fuel.

Over-inflation results in an uncomfortable ride, a reduced contact area with the road and accelerated wear on the tread centre. It also makes the tyre more susceptible to impact damage.

Tyre inflation pressure should be checked every two weeks using an accurate pressure gauge regardless of whether the vehicle is fitted with a Tyre Pressure Monitoring System.

Pressure should be checked only when the tyre is cold, since there is an increase in pressure when the tyre has warmed up after being run.



**CORRECTLY
INFLATED
FOR LOAD**

**CONTACT WITH ROAD
EVEN ACROSS TREAD
WIDTH**



**OVER
INFLATED
FOR LOAD**

**CONTACT WITH ROAD
IN CENTRE OF TREAD**



**UNDER
INFLATED
FOR LOAD**

**CONTACT WITH ROAD
CONCENTRATED ON
TREAD EDGES**



TYRE PRESSURE MONITORING SYSTEMS (TPMS)

TPMS is a system fitted to a vehicle which constantly monitors the pressures or pressure imbalance in the tyres and provides a warning to the driver if these fall below a certain threshold.

Such is the importance of correct inflation, TPMS is a very useful safety feature. However, TPMS should not be seen as a replacement for regular manual tyre safety checks.

Two types of TPMS systems are fitted on cars today. Direct systems use radio sensors mounted inside of each wheel to measure the tyre inflation pressures. Indirect systems utilise the vehicle's existing ABS sensors to measure and compare the rotational speeds of the tyres, which are affected by their pressures. Both types work with the vehicle's main Electronic Control Unit (ECU) to alert the driver via dashboard warning lights to any pressure loss or variance issues.

TPMS AND THE LAW

Since November 2014, all new passenger vehicles sold in the EU must be equipped with TPMS.

Furthermore, with effect from 1st January 2015, all vehicles fitted with TPMS when new will need to have a fully functioning system when undergoing their annual MOT test. Inoperative or faulty TPMS systems will result in an MOT failure.

TPMS AND RUNFLAT TYRES

Runflat tyres are designed to provide a limited run-on period following a puncture. These types of tyres can be identified by the "RF" marking found on the tyre sidewall.

Runflat tyres are only designed to run for a limited period, at a maximum speed of 50 mph with a limited load carrying capacity.

Due to the nature of runflat tyres, these should only ever be fitted to vehicles equipped with TPMS.

TPMS SERVICING

To ensure your TPMS system continues to operate properly and reduce the likelihood of an MOT failure, it may be necessary to have the system serviced occasionally. TPMS sensors are designed to last for many years and miles, however, after a certain period, the sensor's internal battery will run out meaning a replacement is needed.

In addition, sensors can become faulty or fail completely as a result of weather damage, corrosion or accidental damage caused when changing tyres. To ensure the sensor remains in good condition, many manufacturers recommend replacement of the valve cap and core components every time a tyre is changed.

When replacement TPMS sensors are fitted to your vehicle, your tyre fitter may need to programme the new component to the car using specialist diagnostic equipment.

If your TPMS sensor does develop a fault, under no circumstances should this be removed and replaced with a 'standard' non-TPMS type valve. Removing the sensor will not only reduce your safety on the road, it will also result in your car failing its MOT.

TPMS WARNING LIGHTS

If the TPMS warning light on your dashboard illuminates, this should not be ignored as there may be a problem with the pressure in one or more of your tyres. At the earliest opportunity, find a safe place to stop your vehicle where you can manually check your tyre pressures against the vehicle manufacturer's recommended settings. These details can be found in your vehicle handbook, inside the fuel filler flap or on a placard located on the driver's door sill.

If you are unable to check your pressures yourself, either call for roadside assistance or locate your nearest tyre professional who will be able to help you.

MANUAL CHECKS

While the benefits of TPMS are widely recognised, it is important that they are not seen as a replacement for regular manual tyre safety checks. Pressures should be tested at least once a month or before any long journey, when the tyres are cold using an accurate and reliable pressure gauge.

When checking pressures, it is advisable to also give the rest of the tyre a thorough visual inspection as well as ensuring the tread is not excessively or unevenly worn.





INSPECTION AND MAINTENANCE

Tyres should be examined frequently, removing stones or other embedded objects from the tread. If the tyre has lumps or bulges it must be examined by a tyre specialist since these could indicate internal damage. Remove oil or grease with a suitable diluted detergent.

WATCH YOUR TREAD

The legal minimum tread depth in the UK is 1.6mm across a continuous band comprising the central three-quarters of the breadth of tread and round its entire circumference. Tyre treads are designed to give good grip on wet roads but in general wet grip decreases as the tyre tread depth approaches the legal minimum. Motorists should take this into consideration and reduce speed when driving in wet conditions. For the same

reason motorists may wish to consider replacing tyres before the tread depth reaches the legal minimum.

CARAVANS AND CAR TRAILERS

See the TyreSafe leaflet “Caravan tyres and your safety” for specific advice on this topic.

Caravan and trailer tyres often require higher inflation pressures than are required for the same tyres on a car. It is essential to identify and maintain correct tyre pressures.

In the absence of any recommendation in the vehicle handbook regarding car tyre inflation when towing, increase the towing vehicle’s rear tyre pressures by 4 to 7 psi (0.3 to 0.4 bar) to improve the stability of the complete unit.

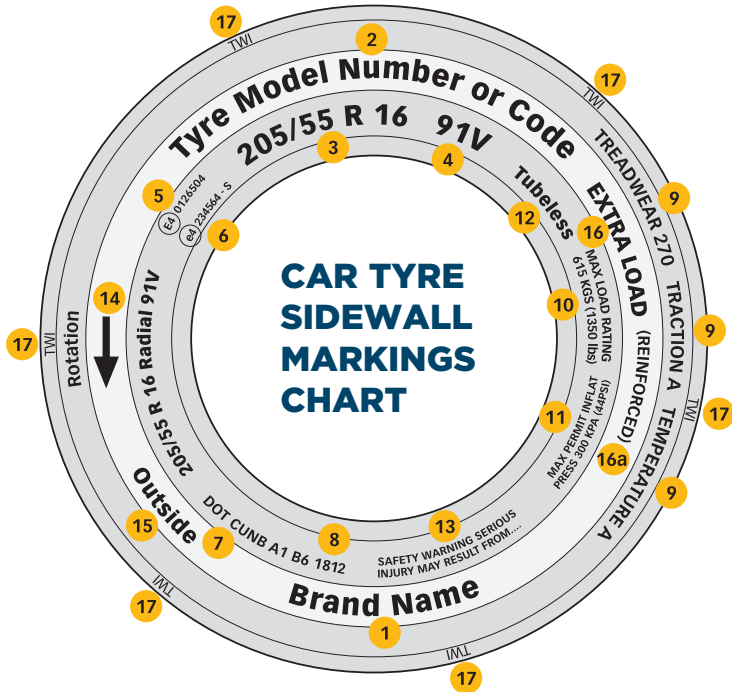

- | | |
|--|---|
| <ul style="list-style-type: none"> 1 Manufacturer's name or Brand name 2 Model or Pattern Code 3 Tyre Size, Nominal Section width(mm), Height to width aspect ratio, Rim diameter code 4 Service description (Load Index + Speed Symbol) 5 ECE R30 Conformity Approval Number 6 EEC Noise Approval Number 7 USA Dept of Transport Manufacturer's code 8 Date of Manufacture 9 USA UTQG Quality Grades ** 10 USA Maximum Tyre Loading ** 11 USA Maximum Tyre Inflation Pressure ** 12 Denotes Tubeless Construction | <ul style="list-style-type: none"> 13 Safety Warning 14 Direction of Rotation [Directional Tyres only] 15 Outer (Inner) sidewall [Asymmetric Tyres Only] 16 Extra Load: Denotes higher load capacity than standard tyre. 16a "Reinforced" is an alternative marking to "Extra Load" 17 TWI-Tread Wear Indicators- raised areas at the base of the tread grooves to serve as a visual warning of when the tyre is approaching or at the minimum legal limit. <p>** These markings are required by North American legislation and have no significance in the UK & Europe</p> |
|--|---|

TEMPORARY USE SPARE TYRES

Temporary use spare tyres are frequently of a different size to the standard road tyres and operating restrictions apply. Failure to observe the advice given in the vehicle handbook and/or on the spare wheel or tyre sidewall could have very serious consequences.

Do not exceed the recommended maximum speed when using a temporary use spare tyre and observe the minimum inflation pressure.

TEMPORARY TYRE REPAIR KITS

Many cars are now equipped with a temporary puncture repair kit rather than a spare tyre. See owner's handbook on how to use and remember this is only a temporary and not permanent puncture repair.

VALVES

Valves should be replaced or serviced when renewing tubeless tyres. When checking or adjusting inflation

pressure, always ensure the valve is not leaking. A new cap of the sealing type should be fitted.

TYRE REPAIRS

Repairs to car tyres must only be carried out by a tyre specialist and in accordance with the current British Standard AU159.

Permanent repairs can only be carried out following removal of the tyre from the wheel to allow a thorough inspection internally as well as externally to ensure there is no hidden damage which could result in a catastrophic failure.

To avoid such a hazard, neither externally applied plug repairs, nor liquid sealants can be considered to be a permanent repair. Tyre manufacturers cannot be held responsible for problems resulting from their use.

For repairs to self supporting run flat tyres, consult the relevant tyre manufacturer.



WHEELS AND RIMS

It is essential that rim and tyre sizes are matched in accordance with the tyre manufacturer's recommendations and that the assembly is an approved fitment for the vehicle concerned. Tyres must not be used on damaged, distorted or modified rims since this could result in tyre damage, deflation and possible loss of control of the vehicle.

REMOVAL AND FITTING OF TYRES

These operations should only be entrusted to a trained tyre specialist who has the necessary equipment and expertise. Inexpert fitting can result in operator injury and damage to tyres and rims. Wheels should be balanced after tyres are fitted or replaced.

TYRE 'LOAD' AND 'SPEED' MARKINGS

With few exceptions, new or retreaded tyres are required by law to carry

indications of the tyre's load carrying and speed capabilities e.g. 205/55R16 91V. These are moulded on the sidewall as a Load Index (e.g. '91' in table 1) for load carrying capacity and a Speed Symbol (e.g. 'V' in table 2) for speed capability.

It is strongly recommended to always fit tyres that have a speed capability and load index at least equal to those originally specified by the vehicle manufacturer.

GENERAL INFORMATION

Driving over pot-holes, kerbs, etc, even at low speed, can result in the weakening or fracture of the tyre's inner structure. It may be dangerous to re-inflate a tyre which has been run flat or seriously under inflated and such tyres should be removed for comprehensive examination by a tyre specialist.

TABLE 1: LOAD INDICES AND RELATED MAXIMUM LOADS

Load Index	Load KG	Load Index	Load KG	Load Index	Load KG	Load Index	Load KG	Load Index	Load KG
50	190	65	290	80	450	95	690	110	1060
51	195	66	300	81	462	96	710	111	1090
52	200	67	307	82	475	97	730	112	1120
53	206	68	315	83	487	98	750	113	1150
54	212	69	325	84	500	99	775	114	1180
55	218	70	335	85	515	100	800	115	1215
56	224	71	345	86	530	101	825	116	1250
57	230	72	355	87	545	102	850	117	1285
58	236	73	365	88	560	103	875	118	1320
59	243	74	375	89	580	104	900	119	1360
60	250	75	387	90	600	105	925	120	1400
61	257	76	400	91	615	106	950	121	1450
62	265	77	412	92	630	107	975	122	1500
63	272	78	425	93	650	108	1000	123	1550
64	280	79	437	94	670	109	1030	124	1600

TABLE 2: TYRE SPEED SYMBOL MARKING

Speed Symbol	Maximum vehicle speed for which tyre is suitable	
M	81 mph	130 km/h
P	93 mph	150 km/h
Q	99 mph	160 km/h
R	106 mph	170 km/h
S	112 mph	180 km/h
T	118 mph	190 km/h
H	130 mph	210 km/h
V	150 mph	240 km/h
W	169 mph	270 km/h
Y	187 mph	300 km/h
ZR	over 150 mph	over 240 km/h

TYRE SERVICE LIFE AND AGEING

Tyres are designed and manufactured to give long service under typical operating conditions. For most tyres replacement will ultimately be triggered by tread wear. However, adverse environmental, operational or storage conditions can make replacement necessary before the tread is worn to the legal limit. Tyres should be inspected at least monthly for punctures, cuts, bulges, cracking or any other abnormal visual indications. Particular attention should be paid to tyres that are used infrequently; for example as fitted to spare wheels, trailers, caravans and specialist or collector's vehicles. Motorists should also be attentive to any unusual noise or vibration arising from the tyre whilst driving. If any degradation is found or suspected the consumer is strongly advised to have the tyre inspected as soon as practicable by a tyre service professional.

Some tyre and vehicle manufacturers make recommendations regarding the maximum age of tyres in use. This guidance should always be respected.

HOW TO TELL THE AGE OF A TYRE

Tyres carry a date code moulded into the sidewall. On one side of the tyre there is a 12 character code often marked "DOT". For tyres manufactured after 1999 the last four digits of the code represent the week number and the year of manufacture. For example, a tyre marked XXXX XXXX 3712 was made in week 37 of 2012

DIRECTIONAL AND ASYMMETRIC PATTERNED TYRES

Some tyres have patterns where the direction of rotation is important to achieve their full performance. These are known as 'Directional' pattern tyres and the direction of rotation is marked on the sidewall. Equally, some tyres have patterns which are different on the inner half of the tread compared to the outer half. These 'Asymmetric' tyres have their sidewalls marked 'Outside' and/or 'Inside' or similar wording. It is important with both these types of tyre to observe the fitting markings on the tyre sidewall. In the case of Directional tyres if the spare wheel is used it may be necessary to have the tyre reversed on the rim as soon as conveniently possible after deployment.

VEHICLE MANUFACTURER SPECIFIC MARKINGS

Some tyres are marked for specific vehicle manufacturers e.g. Mercedes or BMW. In most cases, this does not prohibit the tyres from being fitted to any other vehicle, or from non-marked tyres being fitted to the vehicle, but can be used as a guide to identify the homologated specification.

For high performance cars, the specific tyre should be fitted to the vehicle e.g. Porsche or Ferrari. Consult the vehicle handbook or the tyre manufacturer if in any doubt.



TyreSafe[®]

TyreSafe, Peershaws, Berewyk Hall Court,
White Colne, Colchester CO6 2QB

01787 226995 theteam@tyresafe.org

tyresafe.org

Charity Number: 1168354 (England and Wales)